

ALUMINUM CHIPPER BODY

TRUCK BODIES
VOTH
 CUSTOM FABRICATION
 519-842-7200
www.vothtruckbodies.com

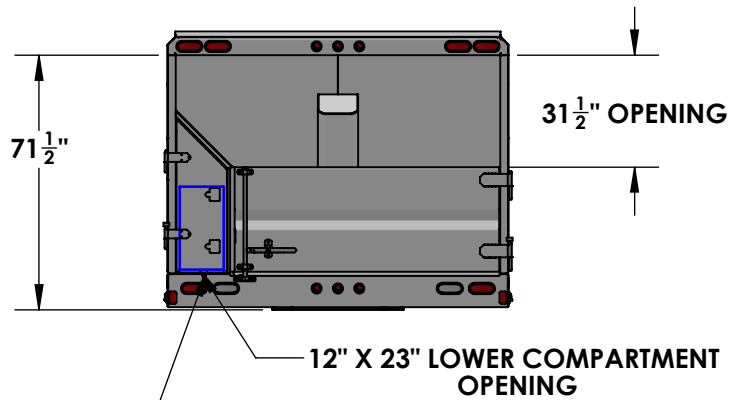
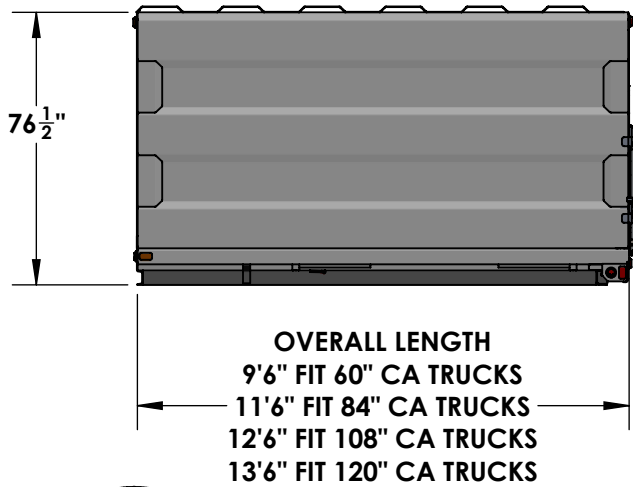

VOTH ALUMINUM CHIPPER BODIES ARE CONSTRUCTED FROM 5083-H321 MARINE QUALITY ALUMINUM FOR SUPERIOR

- STRENGTH
- CORROSION RESISTANCE
- WEIGHT SAVINGS

SIDES, ROOF, AND REAR GATE 3/16" THICK UNIBODY FLOOR 1/4" THICK

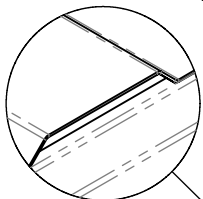

INTEGRATED ROOF VENTS

DOUBLE WALL COMPARTMENT DOOR

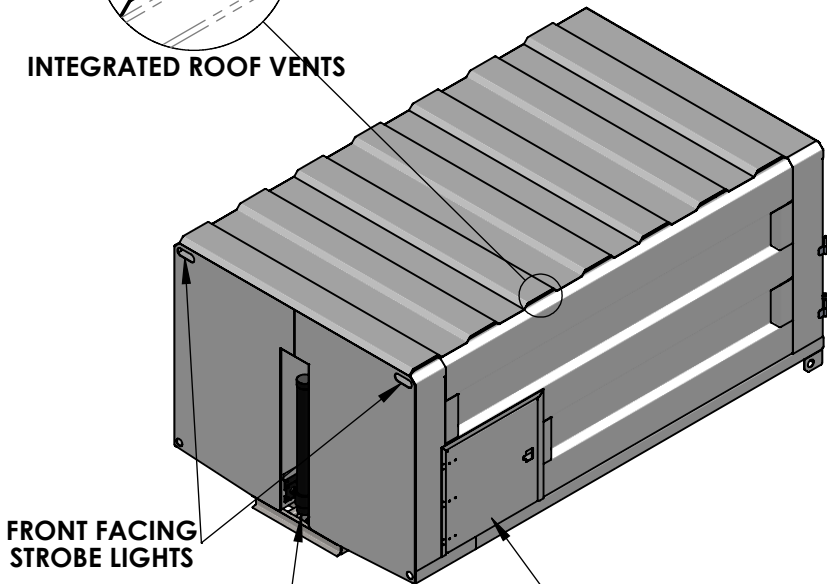

OPTIONAL SIDE DOOR ACCESS TO LADDER COMPARTMENT

FULL LENGTH DRIVER SIDE LADDER/PRUNER COMPARTMENT

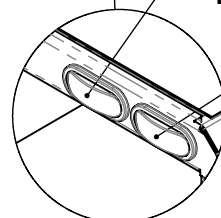
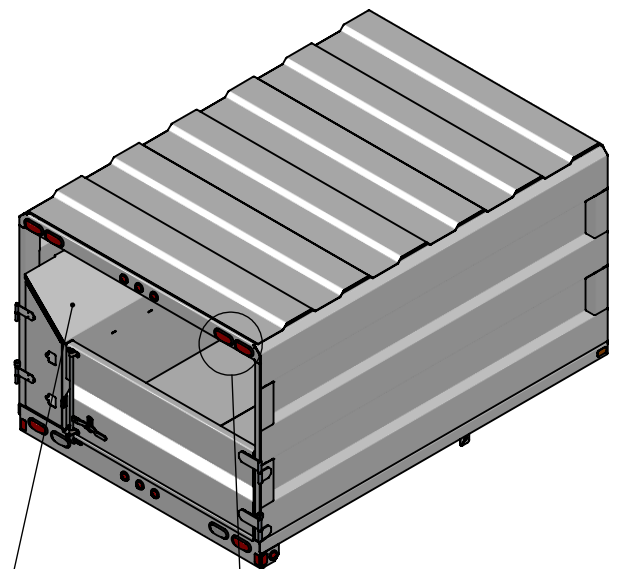

ALL LED LIGHTING