

16'3 DUMP BOX WITH 36" FOLD DOWN SIDES

TRUCK BODIES
VOTH
CUSTOM FABRICATION
519-842-7200
www.vothtruckbodies.com

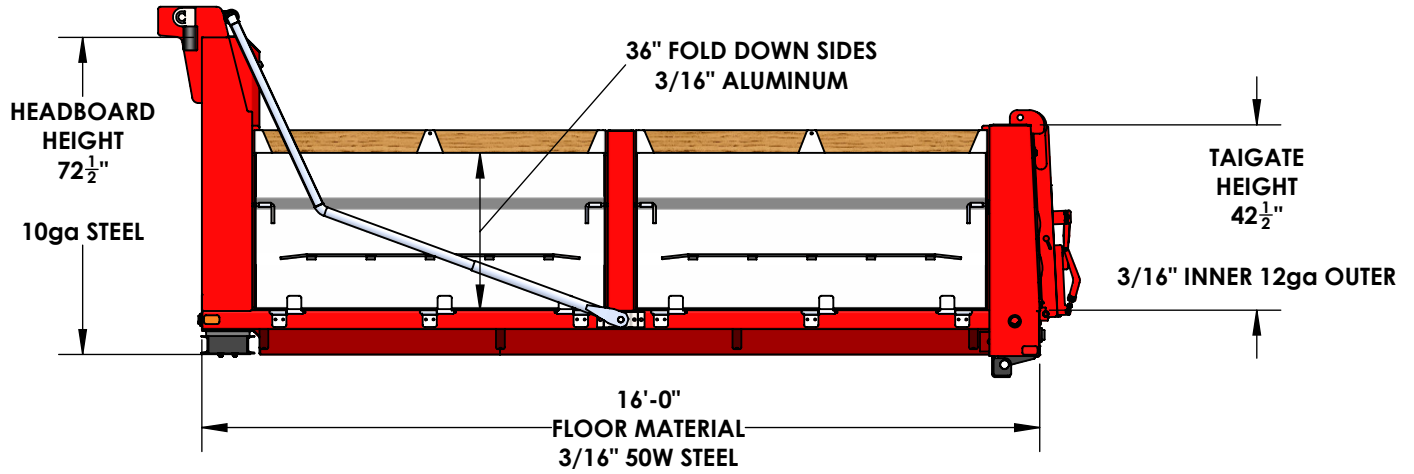

ELECTRIC TARP COVER

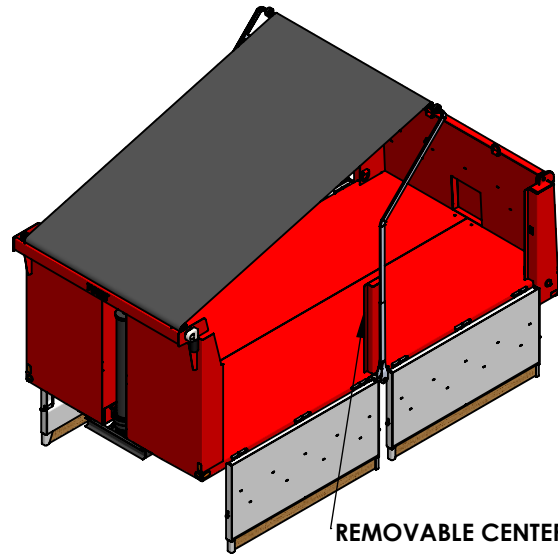
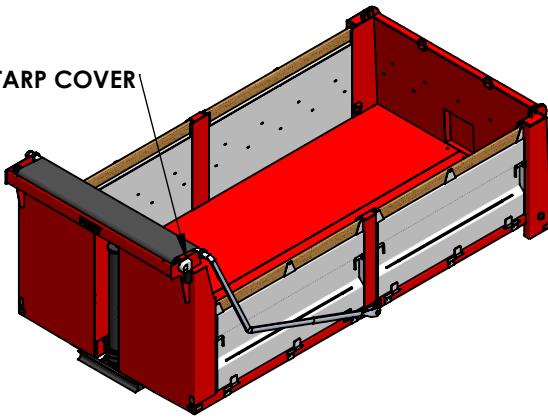

REMOVABLE CENTER POSTS

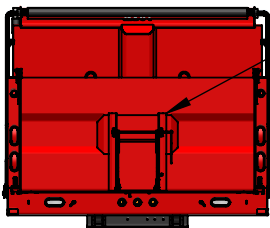

GRAVLE CHUTE
WITH A 15-11/16"
WIDE OPENING

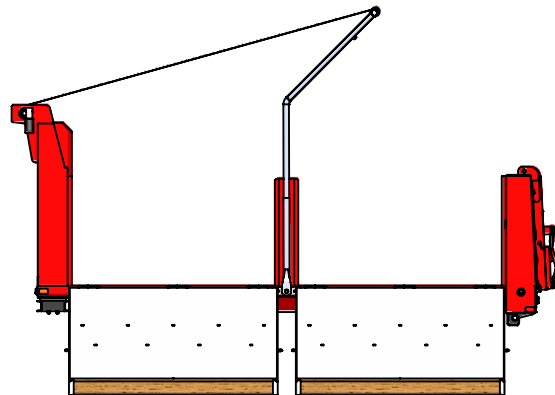

16'3 DUMP BOX WITH 36" FOLD DOWN SIDES



TRUCK BODIES
CORPORATION

519-842-7200
www.vothtruckbodies.com

STRONG UNIBODY DESIGN

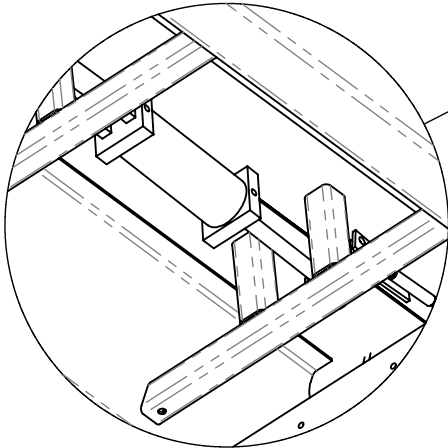

AIR OPERATED TAILGATE RELEASE

30 TON MAILHOT CYLINDER

