



Interchangeable Truck Body System

# DUMP BODY



Switch-N-Go.com • 888 311-0867



## Features

- High quality powder coated finish up to 14'
- Ramp gate for drive-on convenience
- Accepts underbody salt spreader
- 12" side height & 24" tailgate height
- Optional extended board pockets
- Standard 6" steel rollers
- Custom options available

## Distributor Info:

TO FIND A DISTRIBUTOR IN YOUR AREA



## DUMP BODY OPTIONS

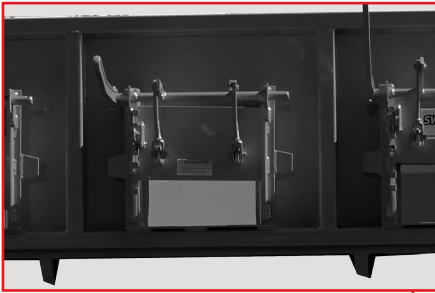

Optional Coal Chute



18" Cabshield Available

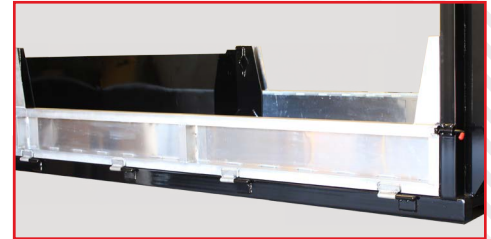

Optional Aluminum or Steel Fold Down Sides

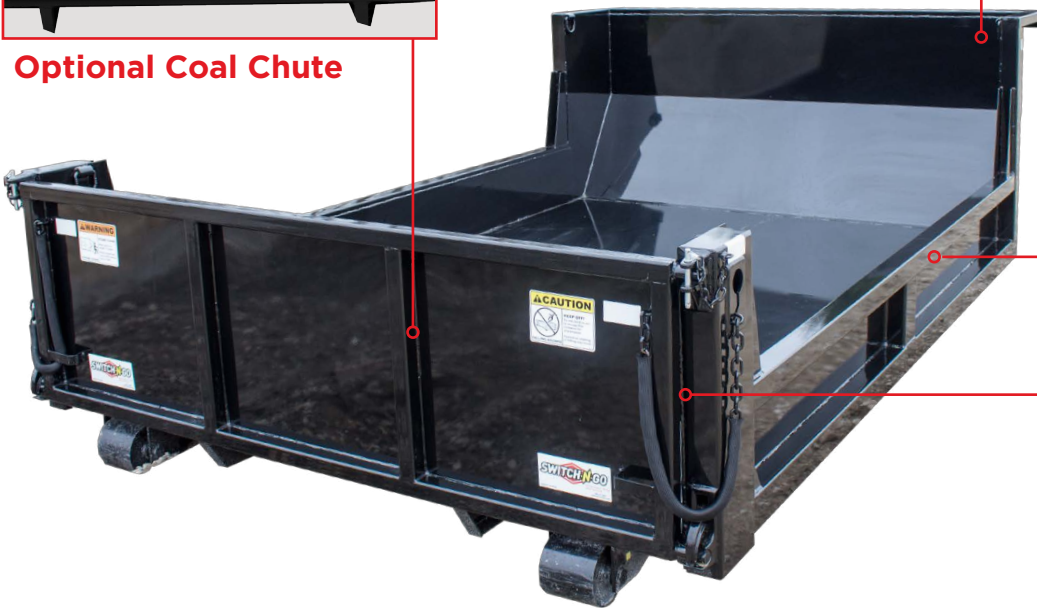

Welded D-rings

## SPECIFICATIONS

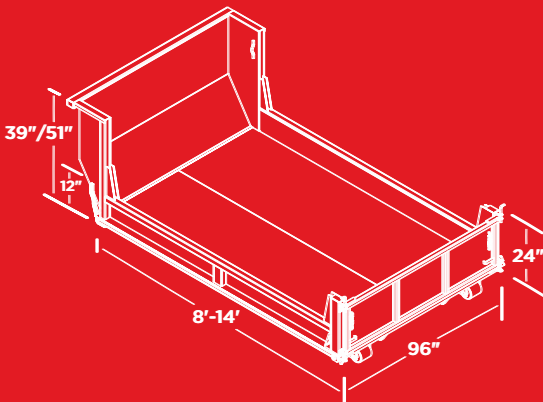

	STANDARD DUTY	HEAVY DUTY
FLOOR	10 GA	3/16"
SIDES	12 GA	10 GA
CROSSMEMBERS	3" STRUCTURAL CHANNEL 16" ON CENTER	3" STRUCTURAL CHANNEL 12" ON CENTER
BULKHEAD	INSIDE HEIGHT 39" OR 51"	
TAILGATE	2" X 2" X 3/16" TUBING & 10GA SHEET	
TOP RAIL	3" X 3" X 1/8"	

Specifications are subject to change with or without notice. Products not warranted for any specific purpose.