

# Maintenance Free, Totally Reliable Electrical Components

Control where & when you need it has been designed into every phase of the TC-131 spreader "ICE CONTROL SYSTEM" for maximum reliability. The Electronic Control Unit (ECU) may be mounted under the dash, or on the transmission tunnel for driver "fingertip" convenience. Power hookup for the system consists of attaching a supplied ENGINE compartment harness to the truck battery, and installing the supplied MOTORS wiring harness and plug receptacle plate from the ECU to the rear of the truck. Now plug in the D-ICER motors' waterproof Packard-style connectors to the plug receptacles to complete the installation. The auger and the spinner are driven by high efficiency electric motors that have been carefully selected for this TruckCraft product to provide both power and reliability. Each motor can be controlled independently on the ECU so that material flow and spread pattern may be tailored for every application. With the advanced technology designed into the ECU, vehicle electrical system parameters and motor amp draw are displayed on the LED readout to let you know exactly what's happening with your system.

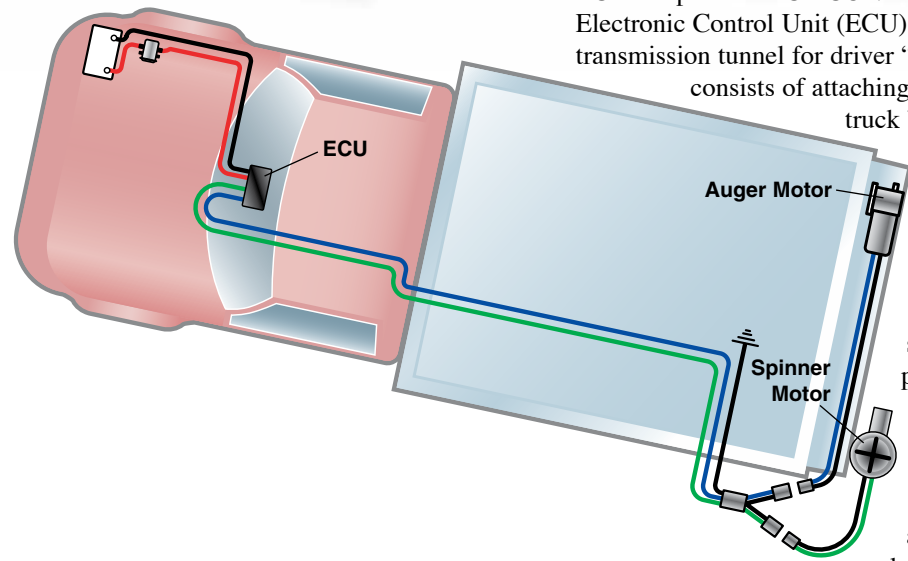

Control where & when you need it has been designed into every phase of the TC-131 spreader "ICE CONTROL SYSTEM" for maximum reliability. The Electronic Control Unit (ECU) may be mounted under the dash, or on the transmission tunnel for driver "fingertip" convenience. Power hookup for the system consists of attaching a supplied ENGINE compartment harness to the truck battery, and installing the supplied MOTORS wiring harness and plug receptacle plate from the ECU to the rear of the truck. Now plug in the D-ICER motors' waterproof Packard-style connectors to the plug receptacles to complete the installation. The auger and the spinner are driven by high efficiency electric motors that have been carefully selected for this TruckCraft product to provide both power and reliability. Each motor can be controlled independently on the ECU so that material flow and spread pattern may be tailored for every application. With the advanced technology designed into the ECU, vehicle electrical system parameters and motor amp draw are displayed on the LED readout to let you know exactly what's happening with your system.

## TruckCraft Products for All Your Hauling, Loading and UNLOADING Needs!!



**TC - 101 MAGNUM** - Our steel pickup insert w/telescopic cylinder. Dumps 6,200 lbs., And has 2.5 cu. yd. cap.; Weighs just 600 lbs. Models for 8 ft. or 6.5 ft. pickups. Pre-assembled unit installs quickly with just two bolts.



**TC - 121 ULTRA** - An all aluminum and stainless steel unit; 7000 lb. and 2.4 cu. yd capacity; Adds approx. 400 lbs. to your truck; For full size pickups; Virtually no maintenance; Greater payloads and hauling volume. Shortbed model available.



**TC - 150 LEAF EXPRESS** - Ten Cu. Yd. aluminum leaf topper quickly converts your aluminum dump insert into a great fall cleanup tool. Hardtop or tarp-top models available - same price.

### Markets Served by TruckCraft Products

- Lawn and Garden Care
- Landscapers
- Nurseries
- Parks and Camp Grounds
- Golf Courses
- Tree Service
- Fire Wood Retailers
- Municipalities
- Roofers
- Small Contractors
- Entrepreneurs
- Farmers

Photos may show optional accessories.



5751 Molly Pitcher Highway South, Chambersburg, PA 17202  
717-375-2900 FAX 717-375-2975

1-800-755-DUMP (3867)  
www.truckcraft.com

TC-130 08/11-3.5m Printed in the USA © 2011 TruckCraft Corporation TruckCraft reserves the right to make product changes and modifications without prior notice.



- All aluminum and stainless steel spreader
- Near "0" maintenance and operational costs
- Fast return on your investment
- Designed to adapt to many pickup dump beds
- Highly reliable electric motors
- Quick installation and removal

# ICE CONTROL SYSTEM

## TC-131 D-ICER™

# Ready to Go in Ice or Snow!

**TRUCKCRAFT**™

**TC-131 D-ICER**



TruckCraft's TC - 131 D - ICER is a premier spreader made entirely of aluminum and stainless steel. The "Ice Control System" is designed to fit our TC - 121 Ultra Aluminum Pickup Dump Bed and, with adapters, other models and brands of pickup dump beds. The new TC - 131 is non-rusting and provides near "0" maintenance and operational costs. TruckCraft uses the highest grade of corrosion resistant aluminum available. All grade A or B - Aluminum Assoc. Standard for grades #6061 and #5052.

**TC-131 consists of three independent components:**

- Tailgate replacement assembly
- Spinner assembly
- Highly reliable electrical components

The D - ICER looks great for years and offers users the performance and convenience needed to produce a quick return on their investment. The unit will handle all free-flowing ice control materials, including sand, salt and aggregate up to 3/4" in diameter. Its low profile allows excellent operator visibility when plowing.

When your wintertime challenges include roads, driveways and parking lots that become covered with ice and snow, hook up your TruckCraft D - ICER and provide safe, clear thoroughfares in no time. After the initial installation (about three hours on the TC -121), loading the TC -131 on to your pickup dump insert can be completed in minutes with only one operator. Don't let those flash snow squalls stymie your winter effectiveness. Serve your customers quickly with TruckCraft's superior "Ice Control System".



## TC -131 Control offers operational flexibility

When the winter winds are howling TC-131 users can complete the entire spreading operation from the comfort of their truck cab. The lighted Electronic Control Module (ECU) may be mounted under the vehicle dash or on the transmission tunnel for easy driver viewing and accessibility. It provides completely independent, variable control of auger & spinner motor speeds, appropriate error codes to let you know the condition of all circuits, and a real-time readout of four critical operating parameters - Spinner & Auger motor amperage draw, vehicle battery voltage, solenoid voltage, and ECU circuit board temperature. Of course, motors & wiring are electronically protected by the ECU current & temperature sensing circuits. An automatic "Overdrive" or "Blast" feature senses a motor jam and tries a set number of times to clear the jam with maximum current before shutting down and flashing an error message to the operator.



## Stainless Steel Auger Conveyor transports 10,000 lbs./hr. of material

The tailgate replacement assembly includes a stainless steel auger that effectively delivers the material to be spread to the driver's side of the truck where it flows onto the spinner. The auger is mounted in non rusting, chemical industry type bearings and utilizes special seals that keep liquids from contacting the bearings. All of these features contribute to longer equipment life. The entire rust resistant assembly is made of aluminum and houses the auger and gearmotor. It has a hinged cover (shown in open position) that can be opened with two sliding-bolt latches to allow quick cleaning of the auger area if a material jam should occur.

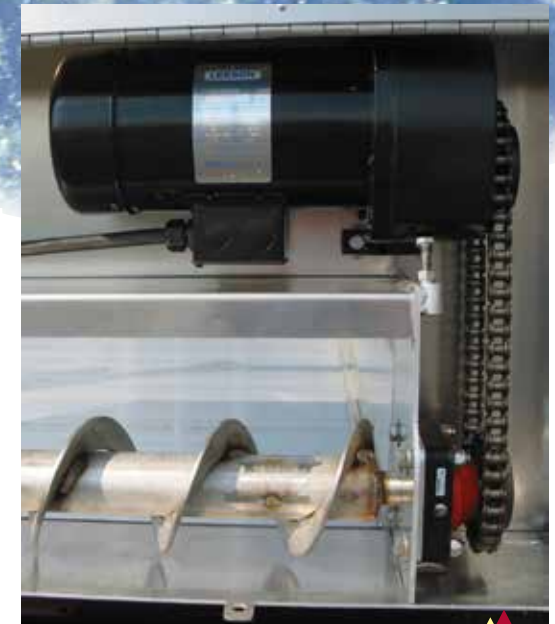

## Custom designed Helical Electric Gearmotor and Chain Drive

The auger is driven by a helical gearmotor that is 97% efficient - that means it doesn't waste your truck's electrical power by generating heat (30% heat-waste in many wormgear reducers). By adjusting the speed of this motor the operator can directly control the amount of material flowing to the spinner assembly. This "flow control" capability is another excellent benefit available from the TruckCraft D-ICER.

## Gear Driven Spinner Assembly distributes the material

The TC-131 spinner is located on the driver's side so the application of material can be seen by the operator. This location also makes it easy to apply material to sidewalks. The spinner drop point is adjustable to provide different spread patterns. A wash-down grade motor typical of those used in the caustic chemical industry provides dependable spinner operation in harsh salt environments. The motor features a 303 stainless steel shaft, double-sealed bearings, is 100% coated inside and out, and is extra-protected from wheel-splash by an aluminum enclosure. A 90 degree gear drive doubles available torque and positions the motor horizontally for maximum road clearance. The spinner assembly is self-leveling, so does not require a link to the bumper, but remains level at all bed positions. The Spinner blades and disc are made of stainless steel for long wear-life.

